

CANALINE

CANALINE

Canal Boat Engines



Canaline 25

Canaline 38

Canaline 42

Canaline 52

Canaline 60

Canaline 70T

Canaline 82T/94T

Engines Plus Ltd



Engines Plus, the manufacturer of the Canaline Marine Engines and the distributor for the Sole Diesel range including the marine generators we offer to this market place.

Engines Plus Ltd is now well established within the UK as a main distributor and importer of petrol and diesel engines and associated equipment. Engines Plus Ltd holds some exclusive rights for the distribution of products including Isuzu diesel engines, Kioti industrial diesel engines, Sole Marine diesel engines and generators, Hyundai Seasall Marine Engines, Yamaha Power Products and Textron Motors.

Engines Plus manufactures the Canaline Marine Engines in the UK, to its own specification which has been put together from many years of experience within this market. Our market knowledge goes back many years and we believe the specification and range of the Canaline product will meet the needs of the customer.

The Kioti core engine powers the majority of the Canaline engines, built in South Korea in a modern factory producing some 40,000 engines per annum.

These engines are fully emission compliant to the RCD 2, but more importantly have proven to be smoke free in locks, which as a customer is key.

Established in 1947, Kioti has become a market leader in the manufacture of diesel engines and agricultural machinery in Korea and has received global acceptance of the products manufactured. The acceptability of Kioti products has resulted in the company becoming firmly established in both the North American and European markets.



Engines Plus at Crick Boat Show



Engine stock at the warehouse

Engines and Generators

The Canaline Marine Engine will offer you many advantages over the competition as we now consider this engine as one of the key engines within this market, buy a Canaline engine, and you will have the following advantages.

- Complete engine range from 22bhp to 94 bhp, ideal for any narrow or wide beam boat
- Largest flywheel on any small engine in the market for smooth running
- Water cooled manifold, to ensure you have quick domestic hot water warm up
- RCD2 compliant engines
- Mechanical fuel injection systems on all engines to ensure simplicity
- The Canaline product has been chosen by leading hire fleets including Black Prince Holidays and Anglo Welsh, to name a few.
- UK Built marinisation
- 3 year self-service warranty



Canaline 25 Marine Diesel Engine



Canaline 52 Marine Diesel Engine



Canaline 70T Marine Diesel Engine

List of Generators

The Sole Diesel generator range is ideal for the inland waterways market, if you are looking for just a small generator for back up, or a larger unit to ensure you have off grid living, we have the options for you. Our product range is proven, tested and reliable and our knowledge of the installation and market will ensure you select the right product

- Complete engine range from 4.0 kva to 115 kva
 - 4.0 Kva not Sole Diesel supply
- Canopied enclosures to ensure low noise
- Water cooled diesel engine
- Mechanical fuel injection systems on all engines to ensure simplicity
- 5 year self-service warranty

AWAITING PICTURE

4kva Marine Generating Set



7GSC Sole Diesel Marine Generating Set



10 GSC Sole Diesel Marine Generating Set

Engine Specifications

RCD2 exhaust emission compliant

4 cylinders (except 3 cylinder for CL 25) diesel engine fitted with large flywheel for smooth engine running

PRM gearbox

Single side servicing, fuel filter, oil filter, air filter and sump pump

4m extension loom, with the first 2m as part of the engine loom to ensure the connection point is not in your bilge but on a bulk head

Mechanical fuel injection pump on all models

Gear driven camshaft

Heavy duty engine mounts for smooth engine running

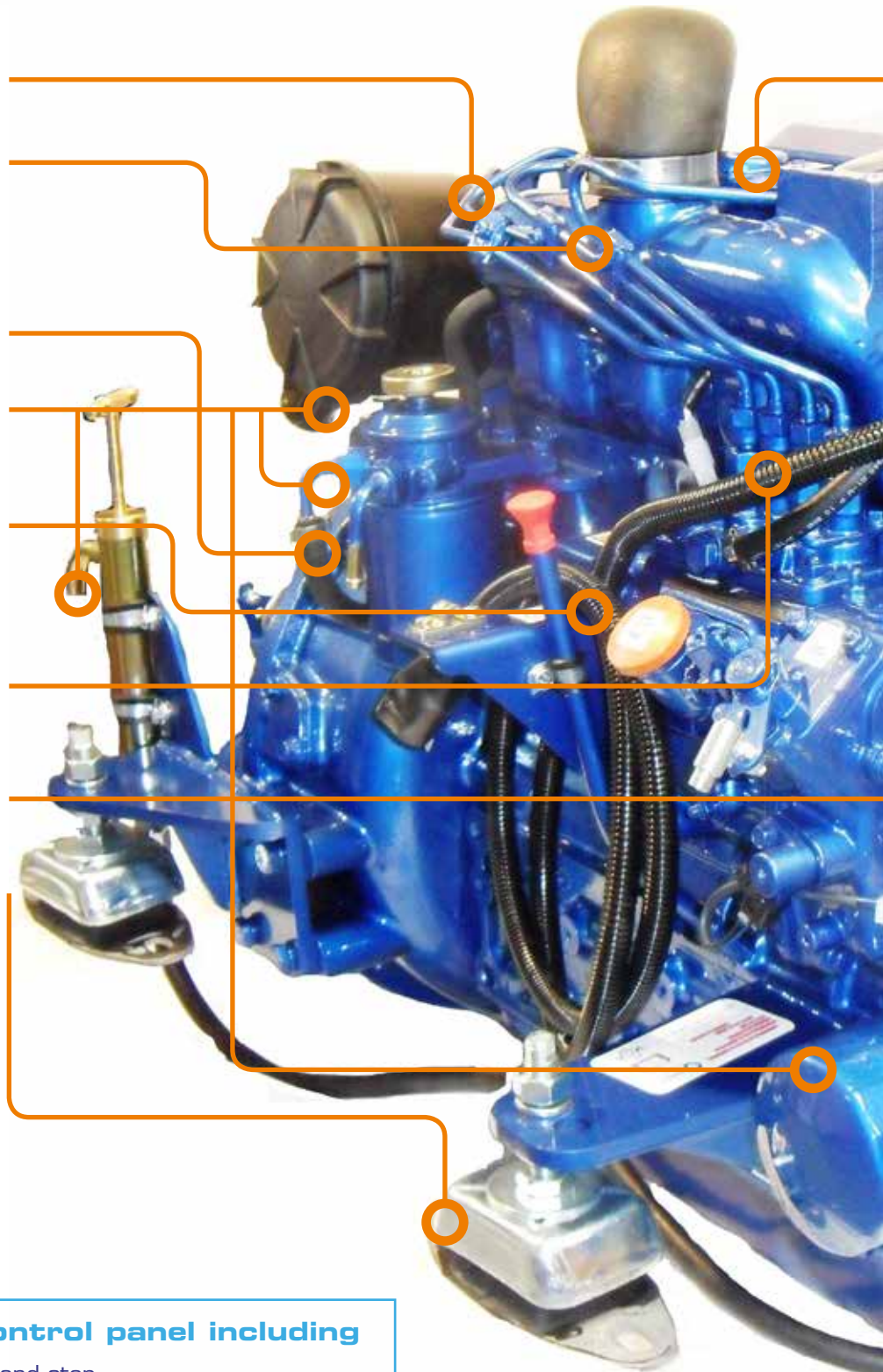

Intermediate engine control panel including



- Key start and stop
- Tachometer with engine hours and voltage indicator for engine battery alternator
- LED indicator and buzzer for low oil pressure, high engine temperature, engine and domestic alternator no charge, pre heat and an on light

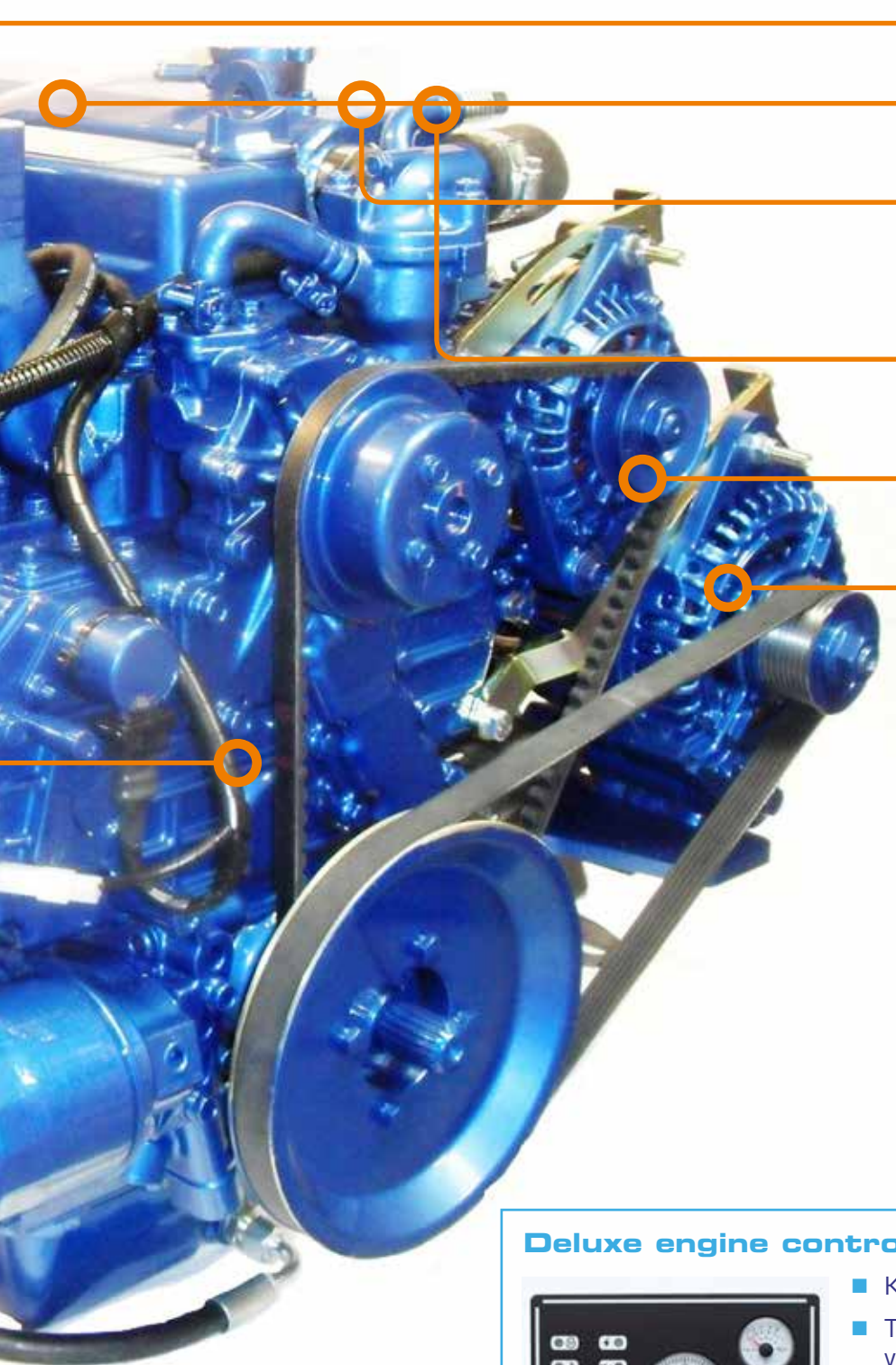

Dry exhaust outlet

Keel cooled with engine mounted header tank

Single side water connections, ensuring short pipe runs to your skin tank

Hot water connections for your calorifer tank as standard

75 Amp engine starter alternators (50 Amp on CL25)

Secondary domestic alternator, 100 Amp on CL 25 and 38 with a 175 Amp fitted on the others, driven a 6PK poly vee belt

Deluxe engine control panel including



- Key start and stop
- Tachometer with engine hours and voltage indicator for engine battery alternator
- Temperature and oil pressure gauge
- LED indicator and buzzer for low oil pressure, high engine temperature, engine and domestic alternator no charge, pre heat and an on light

Canaline 25



Control Panel



Power Curve

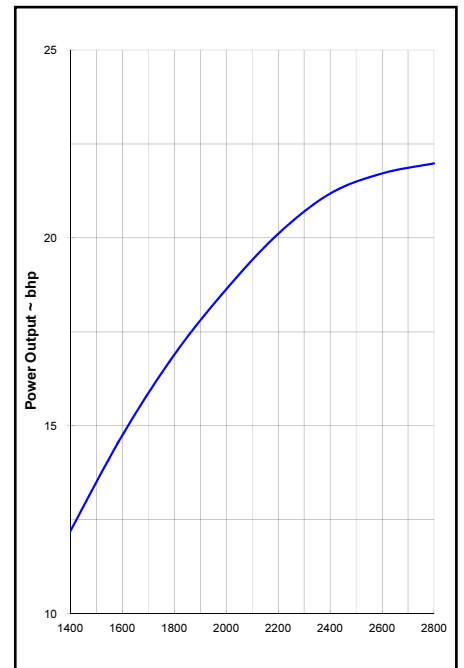

Installation Recommendations

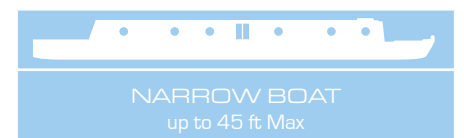

NB: This is only a recommendation, please consult your boat builder for exact recommendations



Twin Alternators

SPECIFICATIONS

General Characteristics	Canaline 25
No of Cylinders	3
Bore x Stroke (mm)	75 x 76
Cubic Capacity	1.007
Maximum bhp	22 @ 2800 r/min
Injection system	Mechanical / Indirect
Intake system	Naturally Aspirated
Cooling system	Keel cooled
12v Electrical System	50A / 100A
Gearbox (pleasure boat only)	PRM 90
Gearbox Ratio (std)	2.04:1
Dry Weight kg (inc gearbox)	145
Exhaust Emissions Compliance	RCD 2

KEY FEATURES

- 3-cylinder Kioti mechanical diesel engine
- 22 bhp @ 2800 r/min
- PRM Marine 90 mechanical gearbox
- Twin 50 Amp & 100 Amp alternators
- Intermediate engine control panel, including tachometer
- Hot water connections
- Fuel filter with built in water trap
- Engine mounted sump pump
- First class dealer network



Fuel Filter with Water Trap



Air Cleaner

Canaline 38



Control Panel



Power Curve

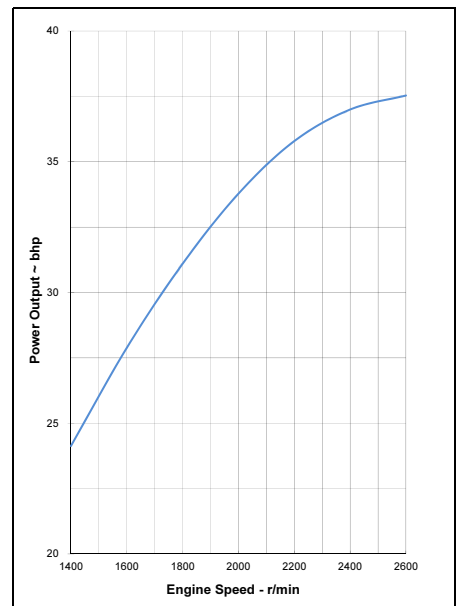

SPECIFICATIONS

General Characteristics	Canaline 38
No of Cylinders	4
Bore x Stroke (mm)	83 x 92.4
Cubic Capacity	1.999
Maximum bhp	38 @ 2600 r/min
Injection system	Mechanical / Indirect
Intake system	Naturally Aspirated
Cooling system	Keel cooled
12v Electrical System	75A / 100A
Gearbox (pleasure boat only)	PRM 125
Gearbox Ratio (std)	2.04:1
Dry Weight kg (inc gearbox)	235
Exhaust Emissions Compliance	RCD 2

KEY FEATURES

- 4-cylinder Kioti mechanical diesel engine
- 38 bhp @ 2600 r/min
- PRM Marine 125 mechanical gearbox
- Twin 75 Amp & 100 Amp alternators
- Intermediate engine control panel, including tachometer
- Hot water connections
- Fuel filter with built in water trap
- Engine mounted sump pump
- First class dealer network

Installation Recommendations



NB: This is only a recommendation, please consult your boat builder for exact recommendations



Single side service points



Hot water connections



Large flywheel

Canaline 42



Control Panel



Power Curve

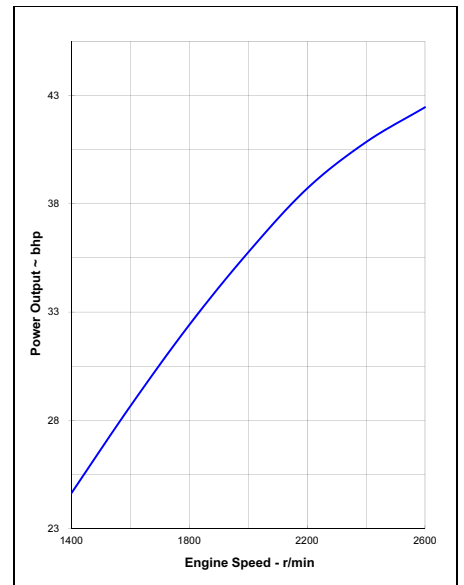

SPECIFICATIONS

General Characteristics	Canaline 42
No of Cylinders	4
Bore x Stroke (mm)	83 x 92.4
Cubic Capacity	1.999
Maximum bhp	42 @ 2600 r/min
Injection system	Mechanical / Indirect
Intake system	Naturally Aspirated
Cooling system	Keel cooled
12v Electrical System	75A / 175A
Gearbox (pleasure boat only)	PRM 150
Gearbox Ratio (std)	2.09:1
Dry Weight kg (inc gearbox)	237
Exhaust Emissions Compliance	RCD 2

KEY FEATURES

- 4-cylinder Kioti mechanical diesel engine
- 42 bhp @ 2600 r/min
- PRM Marine 150 hydraulic gearbox
- Twin 75 Amp & 175 Amp alternators
- Deluxe engine control panel, inc. tachometer and gauges
- Hot water connections
- Fuel filter with built in water trap
- Engine mounted sump pump
- First class dealer network

Installation Recommendations



NB: This is only a recommendation, please consult your boat builder for exact recommendations



Hot water connections



PRM 150 hydraulic gearbox



Gearbox oil cooler kit

Canaline 52

Control Panel



Power Curve

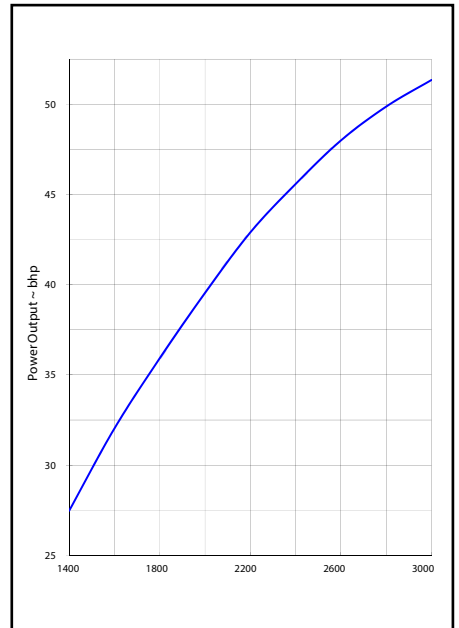

Installation Recommendations

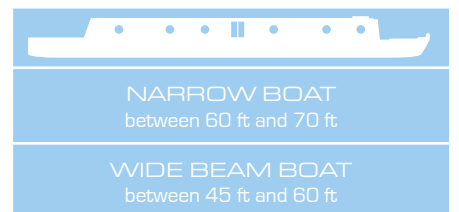

NB: This is only a recommendation, please consult your boat builder for exact recommendations



SPECIFICATIONS

General Characteristics	Canaline 52
No of Cylinders	4
Bore x Stroke (mm)	87 x 92.4
Cubic Capacity	2.197
Maximum bhp	52 @ 3000 r/min
Injection system	Mechanical / Indirect
Intake system	Naturally Aspirated
Cooling system	Keel cooled
12v Electrical System	75A / 175A
Gearbox (pleasure boat only)	PRM 150
Gearbox Ratio (std)	2.09:1
Dry Weight kg (inc gearbox)	248
Exhaust Emissions Compliance	RCD 2

KEY FEATURES

- 4-cylinder Kioti mechanical diesel engine
- 52 bhp @ 3000 r/min
- PRM Marine 150 hydraulic gearbox
- Twin 75 Amp & 175 Amp alternators
- Deluxe engine control panel, inc. tachometer and gauges
- Hot water connections
- Fuel filter with built in water trap
- Engine mounted sump pump
- First class dealer network



Hot water connections



PRM 150 hydraulic gearbox



Twin 75 & 175 Amp Alternators

Canaline 60



Control Panel



Power Curve

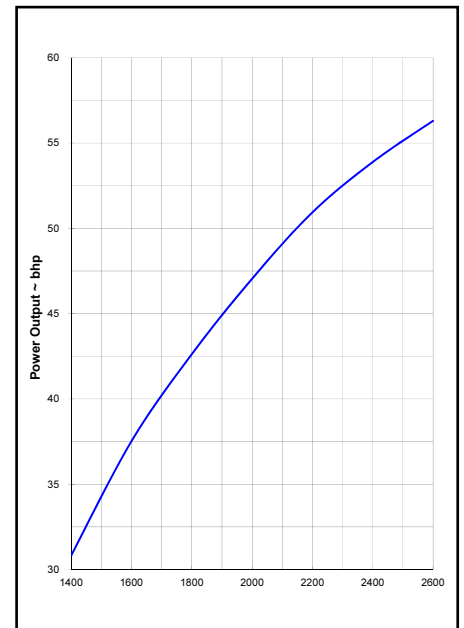

Installation Recommendations

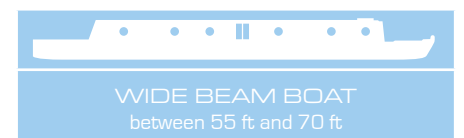

NB: This is only a recommendation, please consult your boat builder for exact recommendations



Twin 75 & 175 Amp Alternators

SPECIFICATIONS

General Characteristics	Canaline 60
No of Cylinders	4
Bore x Stroke (mm)	87 x 102.4
Cubic Capacity	2.435
Maximum bhp	57 @ 2600 r/min
Injection system	Mechanical / Indirect
Intake system	Naturally Aspirated
Cooling system	Keel cooled
12v Electrical System	75A / 175A
Gearbox (pleasure boat only)	PRM 150
Gearbox Ratio (std)	2.09:1
Dry Weight kg (inc gearbox)	256
Exhaust Emissions Compliance	RCD 2

KEY FEATURES

- 4-cylinder Kioti mechanical diesel engine
- 57 bhp @ 3000 r/min
- PRM Marine 150 hydraulic gearbox
- Twin 75 Amp & 175 Amp alternators
- Deluxe engine control panel, inc. tachometer and gauges
- Hot water connections
- Fuel filter with built in water trap
- Engine mounted sump pump
- First class dealer network



Water cooled manifold



PRM 150 hydraulic gearbox

Canaline 70T



Control Panel



Power Curve

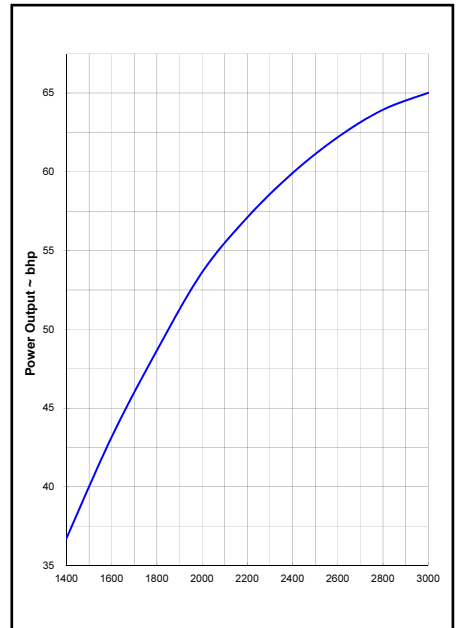

SPECIFICATIONS

General Characteristics	Canaline 70T
No of Cylinders	4
Bore x Stroke (mm)	87 x 102.4
Cubic Capacity	2.435
Maximum bhp	65 @ 3000 r/min
Injection system	Mechanical / Indirect
Intake system	Turbo charged
Cooling system	Keel cooled
12v Electrical System	75A / 175A
Gearbox (pleasure boat only)	PRM 150
Gearbox Ratio (std)	2.09:1
Dry Weight kg (inc gearbox)	256
Exhaust Emissions Compliance	RCD 2

KEY FEATURES

- 4-cylinder Kioti mechanical diesel engine
- 65 bhp @ 3000 r/min
- PRM Marine 150 hydraulic gearbox
- Twin 75 Amp & 175 Amp alternators
- Deluxe engine control panel, inc. tachometer and gauges
- Hot water connections
- Fuel filter with built in water trap
- Engine mounted sump pump
- First class dealer network

Installation Recommendations

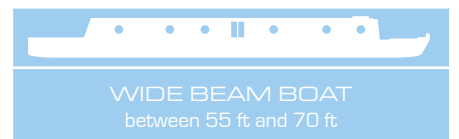

NB: This is only a recommendation, please consult your boat builder for exact recommendations



Twin 75 & 175 Amp Alternators



Hot water connections



PRM 150 hydraulic gearbox

Canaline 82T/94T



Control Panel



Power Curve

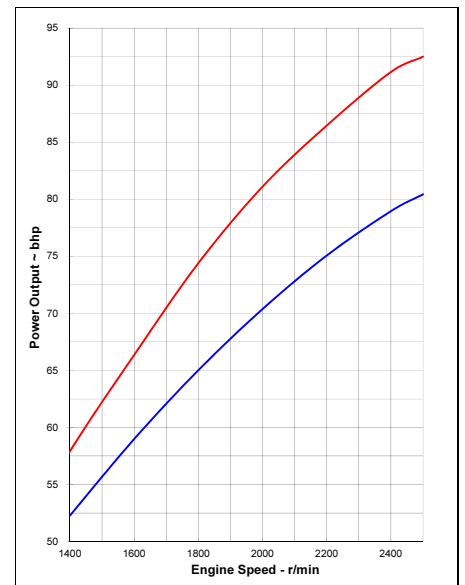

SPECIFICATIONS

General Characteristics	Canaline 82T/94T
No of Cylinders	4
Bore x Stroke (mm)	94 x 120
Cubic Capacity	3.331
Maximum bhp	82/94 @ 2500 r/min
Injection system	Mechanical / Direct
Intake system	Turbo charged
Cooling system	Keel cooled
12v Electrical System	95A / 175A
Gearbox (pleasure boat only)	PRM 280
Gearbox Ratio (std)	1.96:1
Dry Weight kg (inc gearbox)	388
Exhaust Emissions Compliance	RCD 2

KEY FEATURES

- 4-cylinder Mitsubishi mechanical diesel engine
- 82 bhp / 94 bhp @ 2500 r/min
- PRM Marine 280 hydraulic gearbox
- Twin 95 Amp & 175 Amp alternators
- Deluxe engine control panel, including tachometer and gauges
- Hot water connections
- Fuel filter with built in water trap
- Engine mounted sump pump
- First class dealer network

Installation Recommendations

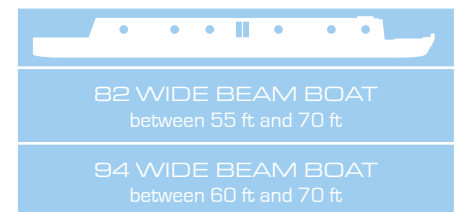

NB: This is only a recommendation, please consult your boat builder for exact recommendations



Water cooled manifold



RM 280 hydraulic gearbox



Turbo charged mechanical engine

Optional Accessories

As part of your package from Engines Plus we can offer you a range of optional accessories, to enhance your engine or generator, we have many options from upgrading your panel, alternators or gearbox or adding the Whisper Power belt power system, please consult our price list for all the options, but generally we can upgrade your engine as follows:



Alternative gearboxes



Higher output alternators



Deluxe or alternative control panels

Installation Accessories

The installation is crucial to ensure your engine or generator works perfectly within your boat, at Engines Plus we have only selected the right products to match our Canaline engine or Sole Diesel generator, our installation accessories included

- Propeller and stern gear assemblies
- Control lever and cables
- Fuel pre filter and ISO fuel hoses
- Exhaust systems for both engine and generator
- Hospital type silencers



Gensets

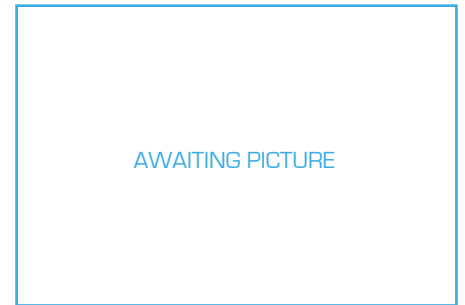

Engines Plus are able to offer a range of generators ideal for your narrow or wide beam boat from our partnership with Sole Diesel.

The Sole Diesel generators are manufactured to suit this market place, and have key features including:

- Complete engine range from 4.0 kva to 115 kva
 - 4.0 Kva not Sole Diesel supply
- Canopied enclosures to ensure low noise
- Water cooled diesel engine
- Mechanical fuel injection systems on all engines to ensure simplicity
- 5 year self-service warranty

Sole Diesel believes in leading the way with product innovation, continuous product improvements and an effective after sales and service network to ensure all customers' expectations are met. Our international distributors with their own local network of chandleries and workshops, it's proof of how important after sales service is for us.



7GSC



7GSC Control panel

Model	Output	Rpm	Canopy	Cooling	Exhaust	Application
4KVA	4.0 kva	3000	Yes	Heat exchanger	Wet Exhaust	Ideal for back up, but not continuous use
7GSC	6.6 kva	1500	Yes	Heat exchanger	Wet or dry Exhaust	Ideal for off grid living, Quiet due slow speed running
10 GSC	9.4 kva	1500	Yes	Heat exchanger	Wet or dry Exhaust	Ideal for off grid living, Quiet due slow speed running
14 GSC	13.9 kva	1500	Yes	Heat exchanger	Wet or dry Exhaust	Ideal for off grid living, Quiet due slow speed running

Larger generators on request

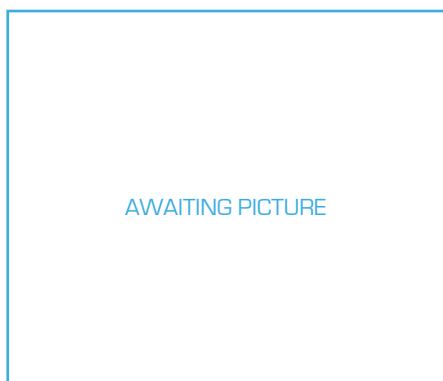

4kva Marine Generating Set



7GSC Sole Diesel Marine Generating Set



10GSC, showing engine

General Arrangements

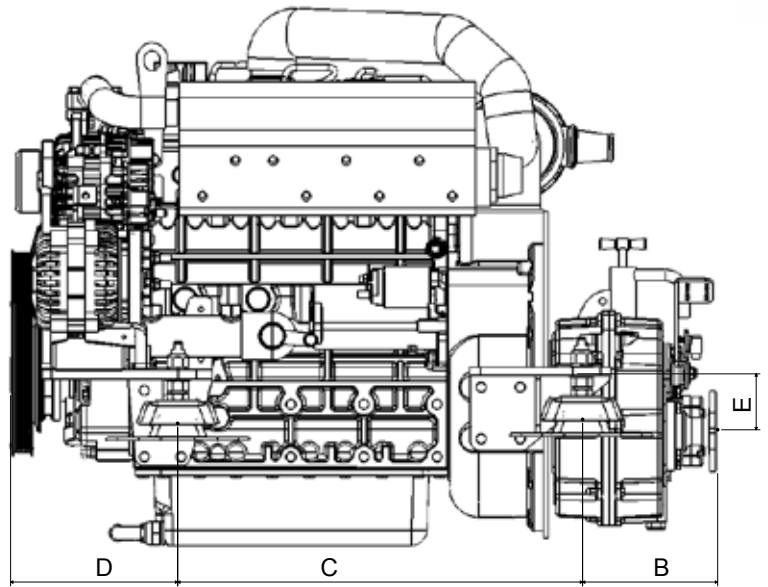
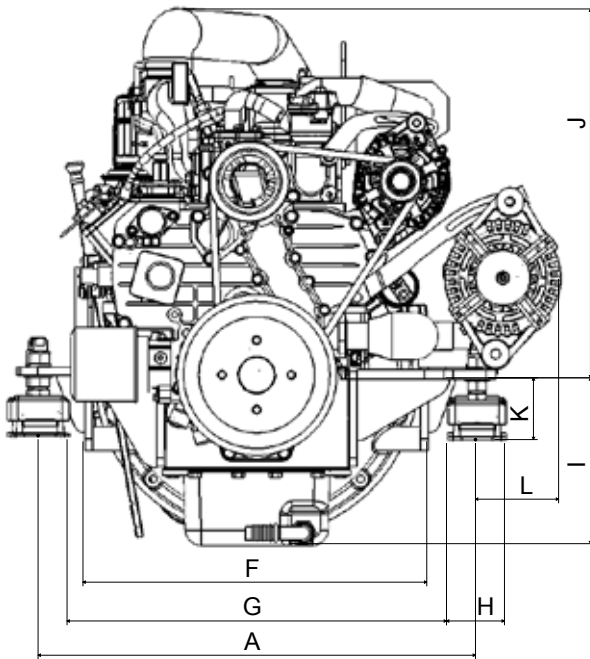

Model	A	B	C	D	E	F	G	H	I	J	K	L
Canaline 25	572	216	350	180	67	432	497	75	198	460	80	108
Canaline 30	572	186	450	212	67	472	497	75	205	480	80	108
Canaline 38	572	186	522	235	67	472	497	75	205	480	80	108
Canaline 42	572	185	525	235	69	472	497	75	205	480	80	108
Canaline 52	572	185	525	235	69	472	497	75	205	480	80	108
Canaline 60	572	185	530	235	69	472	497	75	235	555	80	108
Canaline 70T	572	185	530	235	69	472	497	75	235	600	75	108
Canaline 82T/94T	572	258	562	273	88.8	478	492	75	253	500	80	254

Dimensions are for typical engine packages. Consult Engines Plus Ltd for dimensions of specific specifications.

On Canaline 82T/94T the Aux Alternator protrudes from the opposite side of the engine to that shown on the diagram ~ Dimension L.

ENGINE CONTROL PANEL DIMENSIONS (MM)





**MARINE ENGINES
GENERATING SETS
ACCESSORIES**

Unit F, The Aquarius Centre
Edison Close
Waterwells Business Park
Quedgeley, Gloucester
GL2 2FN

Phone +44 (0)1452 729707
Fax +44 (0)1452 725194

Web www.canaline-engines.co.uk